

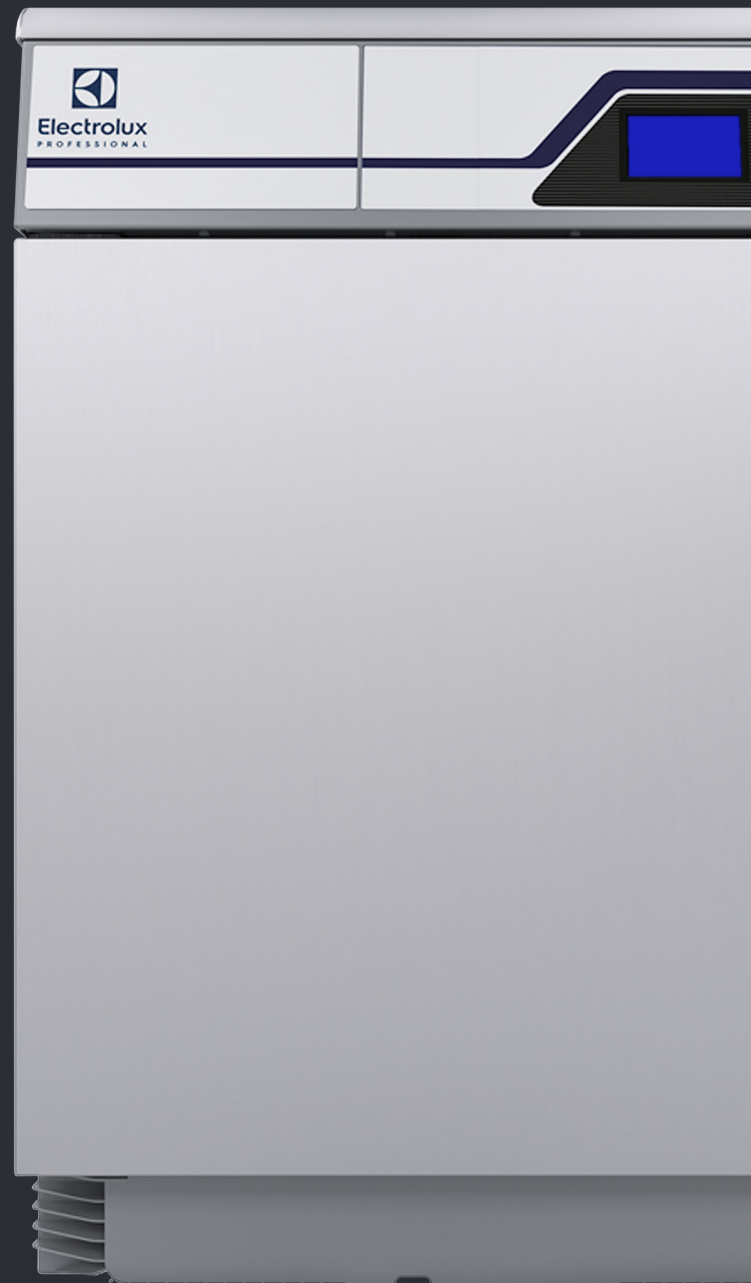

TD6-6LAB+

Standardised
tumble dryer

Sales toolkit



PHYSICAL
PROPERTIES
TESTERS
GROUP

jamesheal.com



Explore the new TD6-6LAB+

Standardised tumble dryer for textile testing. Used to simulate domestic laundering conditions, drying tests and shrinkage testing to meet standard ISO 6330, M&S P1A and AATCC LP1, plus many other test standards.





TD6-6LAB+

The TD6-6LAB+ provides you with repeatable and standard conditions for tumble drying. The test time, temperature and cooling time are preset in accordance with standards.



MODEL NO: **230v – 50Hz** STOCK CODE: **990-186**

MODEL NO: **400v – 50Hz** STOCK CODE: **990-185**

MODEL NO: **230v – 60Hz** STOCK CODE: **990-184**



Key benefits

Accurate and controllable testing

Controllable over exhaust air temperature, testing and cooling times, results in accurate repeatable test conditions.

Compliant to standards

Complies with a range of standards including ISO 6330 edition 4, AATCC LP1 and M&S PG01.

50Hz and 60Hz models

The instrument is available as either 50Hz or 60Hz models.

Easy to use

User-friendly interface controls allowing quick set up and ease of use, with minimal training required.

Quick to maintain

Features an easily removeable lint collection compartment, making it simple to keep running efficiently.

Filter
Removeable lint filter for easy cleaning and maintenance





Display
Intuitive user interface

Durability
Stainless steel top for practicality and longevity of use



Pause test
Opening the door during testing pauses the cycle, which can be restarted using the controls

Alarm
Alarm sounds to alert when testing is complete

Name	Code									
	EN ISO 6330									
	M&S P1A <ul style="list-style-type: none"> • Cellulosic • Synthetics • Wool 									
	<table border="0"> <tr> <td>Next 10</td> <td>Next 34</td> <td>Next 7A</td> </tr> <tr> <td>Next 11</td> <td>Next 36A</td> <td>Next 7B</td> </tr> <tr> <td>Next 12</td> <td>Next 7</td> <td>Next 9</td> </tr> </table>	Next 10	Next 34	Next 7A	Next 11	Next 36A	Next 7B	Next 12	Next 7	Next 9
Next 10	Next 34	Next 7A								
Next 11	Next 36A	Next 7B								
Next 12	Next 7	Next 9								
	Woolmark TM 254 Woolmark TM 31									
	Laboratory Procedure (LP1) <ul style="list-style-type: none"> • Delicate • Normal • Permanent Press 									

01 | **Compliant and customisable**

The TD6-6LAB+ complies with a range of standards and retailer test methods. The test time, temperature and cooling time are preset in accordance with standards.

02 | **Accurate and controllable testing**

To eliminate the issue of reliability and continuity in regular tumble drying machines, the TD6-6LAB+ is specifically designed for standardised testing in laboratories.

Controllable exhaust air temperature, and drying time reduces the machine variables and potential for operator error to the minimum, resulting in accurate repeatable test conditions.

03 | **Intuitive controls**

The various features are easy to navigate with the familiar feel of a domestic device used in every day life, ensuring operation and test set up is very quick and simple to do.

04 | **Durable and robust**

The ergonomic user interface and stainless steel construction provide a practical and robust instrument, which will look great in any lab for many years to come.

05 | **Easy lint removal**

An easy to remove lint compartment accessed from the front of the machine makes the collection and removal of lint a simple and quick task. As with any tumble dryer, keeping the instrument lint free will maintain its efficiency and safety.

06 | **Suitable for use worldwide**

Available in two models, either 50Hz and 60Hz frequency meaning the TD6-6LAB+ is suitable for the majority of countries around the world. To check your location for the correct frequency model, see page 8 for guidance on countries requiring 60Hz models.

07 | **Installation requirements**

There are specific installation and socket requirements to be aware of in advance to ensure your instrument can be quickly set up on delivery. Please check the Installation notes for guidance on page 12.

Listed below are many of the countries which use 60Hz frequency and in which TD6-6LAB+ can now be used. However it must be noted that for supplies lower than 220 V (e.g. USA 120 V) a step-up transformer rated at 5kVA should be used. James Heal do not supply this transformer.

Country	Voltage	Frequency
Brazil	110-220V	60Hz
Mexico	127V	60Hz
Colombia	110V	60Hz
Costa Rica	120V	60Hz
Dominican Republic	110V	60Hz
Ecuador	127V	60Hz
El Salvador	115V	60Hz
Nicaragua	120V	60Hz
Panama	110V	60Hz
Peru	220V	60Hz
Puerto Rico	120V	60Hz
Guatemala	120V	60Hz
Guyana	240V	60Hz
Honduras	110V	60Hz
Honduras	110V	60Hz
Saudi Arabia	127/220V	60Hz
South Korea	220V	60Hz
Philippines	220V	60Hz
Japan	100V	60Hz
Taiwan	110V	60Hz
Canada	120V	60Hz
United States	120/240V	60Hz

Browse our laundrying range to find the right product that meets your testing requirements. Textile laundrying and fastness are at the core for testing nearly all textile materials, and our instruments provide user-friendly function combined with durability and safety.

GyroWash



Colour Fastness to Washing Tester for washing and dry cleaning textiles and leather. Compliant with AATCC and ISO standards and available in either 8 or 20 pot models.

Key Features

- Available as 8 or 20 vessel models
- Quality assured high grade steel
- Touchscreen capacitive display

TruFade



Xenon Arc Light Fastness Tester, used to test the colour fastness to light of textiles, leather and other materials, simplifying a difficult area of light fastness testing

Key Features

- Air-cooled Xenon lamp
- Onboard and in-built weathering
- Tri-sided specimen holders

Wascator



Standardised European Washing Machine for textile laboratories, to determine shrinkage, dimensional stability and appearance after washing.

Key Features

- Available as 8 or 20 vessel models
- Quality assured high grade steel
- Touchscreen capacitive display



Certificate of calibration

202-417	UKAS Certificate of calibration
---------	---------------------------------

Stock code	Item	Details
702-530	Polyester Makeweights- per pack (1kg)	Size: 300 x 300 ± 30mm Weight: 40g (approx) Complies with EN 26330 : 1994, ISO 6330 : 1984 and Next
702-532	100% Polyester Ballast (Type 3)- per pack (1 kg)	Size : 210 x 210 ± 10 mm Piece Mass: 50±5g Comply with M&S P1A, P1C, P3A, P4, P4A, P4B, P4C, P5, P5A, P6, P7, C15 and EN ISO 6330 : 2000/ Amd.1 : 2008 and EN ISO 6330 : 2012
702-536	100% Cotton Ballast (Type 1)- per pack (1 kg)	Size: 92 x 92 ± 2 cm Piece Mass: 320 ± 10 g Complies with: ISO 6330:2012
702-533	Polyester Makeweights- per pack (1kg)	Size: 300 x 300 ± 30 mm Weight: 35±3g Complies with ISO 6330 : 1984, IEC 60456 and AWI/Woolmark TM31

Temperature Recording Strips - 8 Level

Irreversible. Self-Adhesive
Scales: °C and °F, Dimensions: 51 x 18mm (2 x 0.7 in)

Stock code and details

789-541- A 37°- 65°C per pack (10)	789-544- D 160°- 199°C per pack (10)
789-542- B 71°- 110°C per pack (10)	789-545- E 204°- 260°C per pack (10)
789-543- C 116°- 154°C per pack (10)	
The strips are simple-to-read and exhibit a permanent colour change on exposure to the indicated temperature.	

Dimension (mm)	Height	Width	Depth	Approx weight (kg)
TD6-6LAB+	839	597	725	58

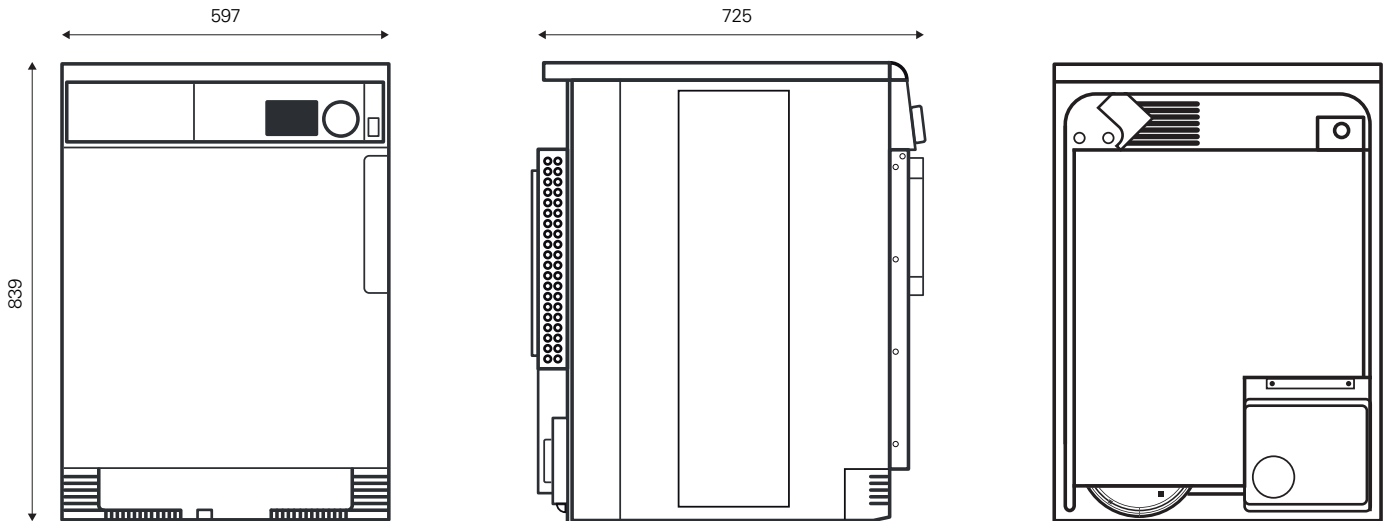

Please note: Technical drawings are illustrations and are not to scale.

Service and calibration

It is recommended that the UKAS accredited TD6-6LAB+ is serviced and calibrated annually by a James Heal Service and Calibration Engineer. Single and multiple year Service and Calibration visits are available.

Item	Comment
Electricity	Single Phase 230V \pm 10%, 50/60 Hz 2600 W (13A)
Air	Not required
Electricity	Designed to be floor standing
Electricity	Not required
Electricity	Not required
Electricity	Designed to be vented through to the open air. The ventilation system, which can be attached to the back or right side of the instrument, should not be joined with any other ventilation system or appliance.
Electricity	Should be positioned in a stable environment.

Electrical connections					
Heating alternative	Main voltage	Hz	Heating power kW	Total power kW	Reccomended fuse A
Electric heated	220V 1 ~	50/60	2.9	3.5	16
	400V 3 ~	50	3.2		10

Connections	TD6-6LAB+
Air outlet (mm)	\varnothing 100
Maximum air flow m ³ /h	150
Condensate	-
Maximum static back pressure Pa	80
Sound levels	
Sound power/pressure level at drying* dB(A)	<70
Heat emission	
% of installed power, max	15
Shipping data**	
net, kg	58
Shipping volume m ³	0.51
Features	
1 Operating panel 2 Door opening \varnothing 370 mm 3 Electrical connection 4 Exhaust connection	

*Sound power levels measured according to ISO 60704.

**Average data. Crated weight/shipping volume depends on configuration. Please contact logistics for exact measures.

To fulfill the requirements in standard ISO 6330 the air flow in the machine needs to be adjusted. Adjustment of air flow is preferably done with an air damper installed in the outlet pipe of the dryer as shown in the diagram below

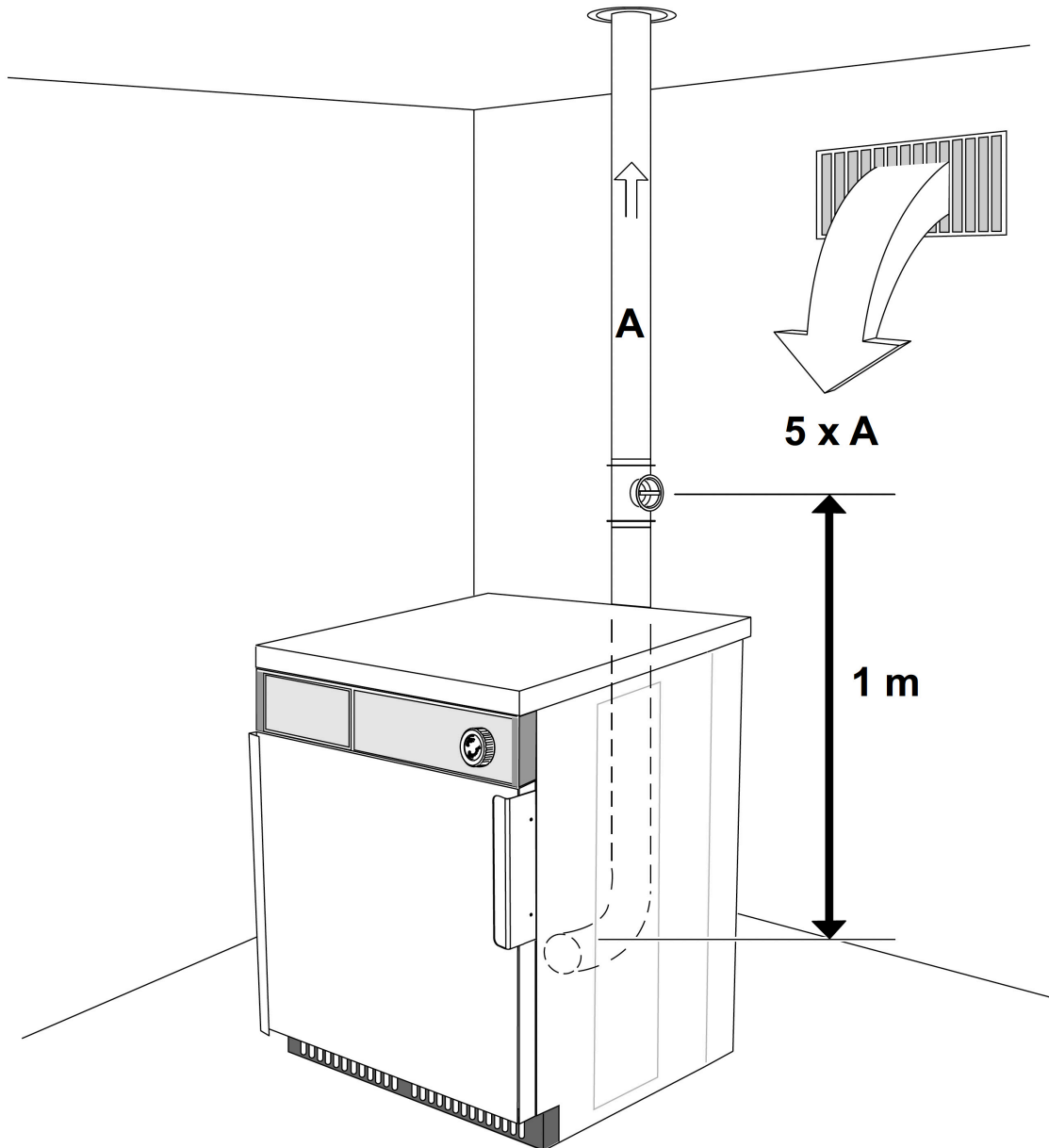

Further information can be found online by clicking on the following:

Data sheet https://6609023.fs1.hubspotusercontent-na1.net/hubfs/6609023/Data%20Sheet%20-%20Electrolux%20TD6-6%20LAB_EN.pdf

Installation Guide https://6609023.fs1.hubspotusercontent-na1.net/hubfs/6609023/Installation%20Manual%20-%20Electrolux%20TD6-6%20LAB_EN.pdf

Operator's Guide https://6609023.fs1.hubspotusercontent-na1.net/hubfs/6609023/Operating%20Manual%20-%20Electrolux%20TD6-6%20LAB_EN.pdf



Find your local James Heal office or sales channel partner at:
jamesheal.com/global-network



jamesheal.com